

VRTÁKY A ZÁHLUBNÍKY
DRILLS
AND COUNTERSINKS
BOHRER UND SENKER
СВЁРЛА И ШЕНКЕРА



BUČOVICE
TOOLS a.s.

STUPŇOVITÉ VRTÁKY STEPPED PEELING DRILLS STUFENBOHRER СТУПЕНЧАТЫЕ СВЁРЛА

		Velikost/Size/ Größe/Размер	Velikost/Size/ Größe/Размер	Velikost/Size/ Größe/Размер	Velikost/Size/ Größe/Размер		
		4/12-1 (č.0/9)	10/20	4/30	6/38 (č.3)		
		4/12-2 (č.0/5)	6/24	6/30	PG4		
			4/20 (č.1)	20/30	PG3		
				6/30 (č.2)	5/35		
				PG1			
				PG2			
		HSS/HSSE	HSS/HSSE	HSS/HSSE	HSS/HSSE		
		n/min	n/min	n/min	n/min		
P	1	700 - 300	600 - 200	600 - 150	600 - 130	0,3 - 4 mm	○
	2	700 - 200	600 - 150	500 - 100	600 - 90	0,3 - 4 mm	○
	3	700 - 300	600 - 200	600 - 150	600 - 130	0,3 - 4 mm	○
	4	600 - 200	600 - 150	500 - 100	500 - 90	0,3 - 4 mm	○
	5						
	6	600 - 200	500 - 150	500 - 100	500 - 90	0,3 - 4 mm	○
	7	600 - 200	500 - 150	500 - 100	500 - 90	0,3 - 4 mm	○
M	1						
	2						
K	1	600 - 200	600 - 150	500 - 100	500 - 90	0,3 - 4 mm	○
	2	600 - 200	500 - 150	500 - 100	500 - 90	0,3 - 4 mm	○
	3	600 - 200	500 - 150	500 - 100	500 - 90	0,3 - 4 mm	○
N	1	600 - 200	500 - 150	500 - 100	500 - 90	0,3 - 4 mm	○
	2	600 - 200	500 - 150	500 - 100	500 - 90	0,3 - 4 mm	○
	3	1300 - 600	1200 - 500	1200 - 400	1200 - 300	0,3 - 6 mm	○
	4	1300 - 600	1200 - 500	1200 - 400	1200 - 300	0,3 - 6 mm	○
	5	1300 - 600	1200 - 500	1200 - 400	1200 - 300	0,3 - 6 mm	○
	6	1300 - 600	1200 - 500	1200 - 400	1200 - 300	0,3 - 6 mm	○
	7	800 - 300	700 - 250	700 - 200	700 - 150	<10 mm	V/O
	8	800 - 300	700 - 250	700 - 200	700 - 150	<10 mm	V/O
S							
H	1						
	2						
	3						

○ Omezené použití / Possible use / Geeignet / Ограниченно
 ● Doporučené použití / Optimal use / Optimal / Оптимально

BUČOVICE
TOOLS a.s.

HSS
code 641 XXX

HSSE
code 691 XXX

HSS TiN
code 646 XXX

HSSE TiN
code 696 XXX

Stupňovité vrtáky
Stepped peeling drills
Stufenbohrer
Ступенчатые свёрла

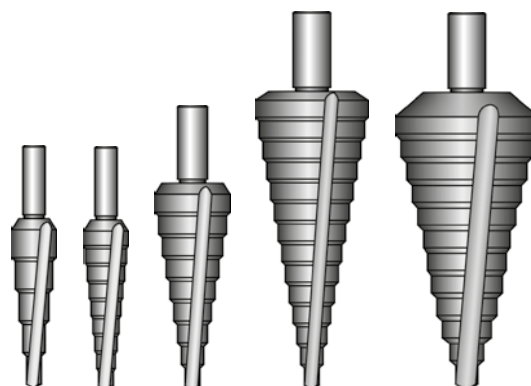
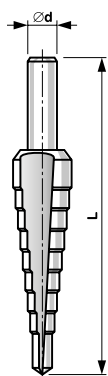

Velikost/Size/Größe/Размер	Ø D	Ø d	L	code HSS	code HSSE
4/12-2 (č. 0/5)	4; 6; 8; 10; 12	6	65	641 005	691 005
4/12-1 (č. 0/9)	4; 5; 6; 7; 8; 9; 10; 11; 12	6	65	641 009	691 009
4/20 (č. 1)	4; 6; 8; 10; 12; 14; 16; 18; 20	8	75	641 010	691 010
10/20	10; 11; 12; 13; 14; 15; 16; 17; 18; 19; 20	10	82	641 027	691 027
6/24	6; 8; 10; 12; 14; 16; 18; 20; 22; 24	10	85	641 013	691 013
4/30	4; 6; 8; 10; 12; 14; 16; 18; 20; 22; 24; 26; 28; 30	13	100	641 015	691 015
6/30 (č. 2)	6; 8; 10; 12; 14; 16; 18; 20; 22; 24; 26; 28; 30	10	100	641 020	691 020
20/30	20; 21; 22; 23; 24; 25; 26; 27; 28; 29; 30	13	88	641 031	691 031
5/35	5; 7,5; 10; 13; 16; 19; 21; 23; 26; 29; 31; 33; 35	13	100	641 025	691 025
6/38 (č. 3)	6; 9; 13; 16; 19; 21; 23; 26; 29; 32; 35; 38	10	100	641 030	691 030

Velikost/Size/Größe/Размер	Ø D	Ø d	L	code HSS TiN	code HSSE TiN
4/12-2 TiN (č. 0/5)	4; 6; 8; 10; 12	6	65	646 005 TiN	696 005 TiN
4/12-1 TiN (č. 0/9)	4; 5; 6; 7; 8; 9; 10; 11; 12	6	65	646 009 TiN	696 009 TiN
4/20 TiN (č. 1)	4; 6; 8; 10; 12; 14; 16; 18; 20	8	75	646 010 TiN	696 010 TiN
10/20 TiN	10; 11; 12; 13; 14; 15; 16; 17; 18; 19; 20	10	82	646 027 TiN	696 027 TiN
6/24 TiN	6; 8; 10; 12; 14; 16; 18; 20; 22; 24	10	85	646 013 TiN	696 013 TiN
4/30 TiN	4; 6; 8; 10; 12; 14; 16; 18; 20; 22; 24; 26; 28; 30	13	100	646 015 TiN	696 015 TiN
6/30 TiN (č. 2)	6; 8; 10; 12; 14; 16; 18; 20; 22; 24; 26; 28; 30	10	100	646 020 TiN	696 020 TiN
20/30 TiN	20; 21; 22; 23; 24; 25; 26; 27; 28; 29; 30	13	88	646 031 TiN	696 031 TiN
5/35 TiN	5; 7,5; 10; 13; 16; 19; 21; 23; 26; 29; 31; 33; 35	13	100	646 025 TiN	696 025 TiN
6/38 TiN (č. 3)	6; 9; 13; 16; 19; 21; 23; 26; 29; 32; 35; 38	10	100	646 030 TiN	696 030 TiN

HSS
code 642 XXX

HSSE
code 692 XXX

Stupňovité vrtáky PG
Stepped peeling drills PG
Stufenbohrer PG
Ступенчатые свёрла PG

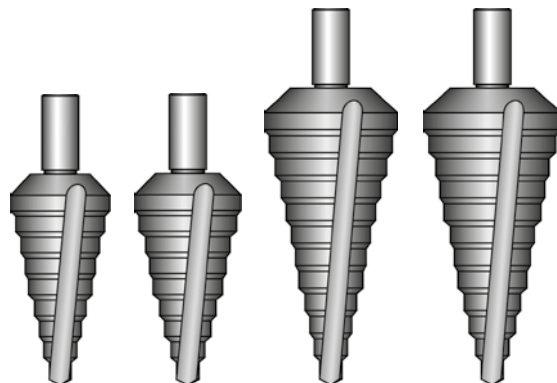
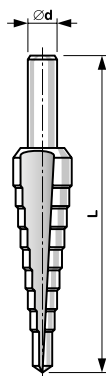

Velikost/Size/Größe/Размер	Ø D	Ø d	L	code HSS	code HSSE
PG 1	6; 9; 11,4; 14; 17,25; 19; 21,25; 26,75	10	77	642 010	692 010
PG 2	6; 9; 12,5; 15,2; 18,6; 20,4; 22,5; 28,3	10	77	642 020	692 020
PG 3	6; 9; 11,4; 14; 17,25; 19; 21,25; 24; 26,75; 30; 33; 35,7	10	100	642 030	692 030
PG 4	6; 9; 12,5; 15,2; 18,6; 20,4; 22,5; 26; 28,3; 30,5; 34; 37	10	100	642 040	692 040

Materiál: HSS; HSSE

Material: HSS; HSSE

Werkstoff: HSS; HSSE

Mamepuan: HSS; HSSE

HSS
code 643 XXX

Stupňovité vrtáky - bit
Stepped peeling drills - bits
Stufenbohrer - Bits
Ступенчатые свёрла - БИТЫ

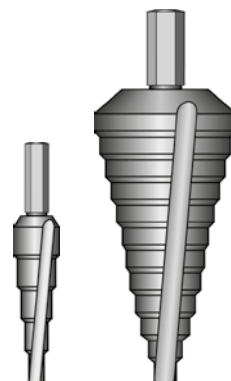
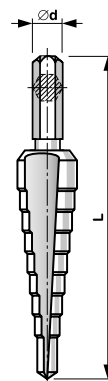

Velikost/Size/Größe/Размер	Ø D	Ø d	L	code
4/12	4; 6; 8; 10; 12	1/4"	54	643 012
4/20	4; 6; 8; 10; 12; 14; 16; 18; 20	1/4"	54	643 010
5/13	5; 7; 9; 11; 13	1/4"	54	643 013
8/20	8; 10; 12; 14; 16; 18; 20	1/4"	67	643 020
9/21	9; 11; 13; 15; 17; 19; 21	1/4"	67	643 021
6/30	6; 8; 10; 12; 14; 16; 18; 20; 22; 24; 26; 28; 30	1/4"	67	643 025

Materiál: HSS

Material: HSS

Werkstoff: HSS

Mamepuan: HSS

 **BUČOVICE**
TOOLS a.s.

HSS
code 648 XXX

HSSE
code 698 XXX

HSS TiN
code 649 XXX

HSSE TiN
code 699 XXX

Stupňovité vrtáky
se šroubovitou drážkou
Stepped peeling drills -
spiral flute
Stufenbohrer -
Rechtsspiralnute
Ступенчатые свёрла -
винтовая дорожка

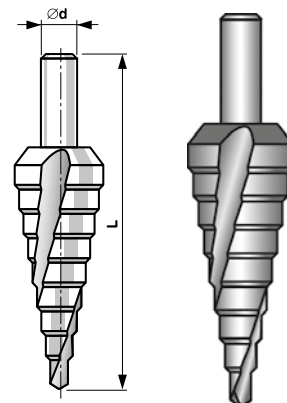

Velikost/Size/Größe/Размер	Ø D	Ø d	L	code HSS	code HSSE	code HSS TiN	code HSSE TiN
4/12-1 (č. 0/9)	4, 5, 6, 7, 8, 9, 10, 11, 12	6	65	648 009	698 009	649 009 TiN	699 009 TiN
4/20 (č. 1)	4, 6, 8, 10, 12, 14, 16, 18, 20	8	75	648 010	698 010	649 010 TiN	699 010 TiN
6/30 (č. 2)	6, 8, 10, 12, 14, 16, 18, 20, 22, 24, 26, 28, 30	10	100	648 020	698 020	649 020 TiN	699 020 TiN
6/38 (č. 3)	6, 9, 13, 16, 19, 21, 23, 26, 29, 32, 35, 38	10	100	648 030	698 030	649 030 TiN	699 030 TiN

Materiál: HSS; HSSE

Material: HSS; HSSE

Werkstoff: HSS; HSSE

Mamepuan: HSS; HSSE

HSS
code 645 XXX

HSSE
code 695 XXX

Stupňovité vrtáky
se šroubovitou drážkou
Stepped peeling drills
PG - spiral flute
Stufenbohrer PG -
Rechtsspiralnute
Ступенчатые свёрла PG
- винтовая дорожка

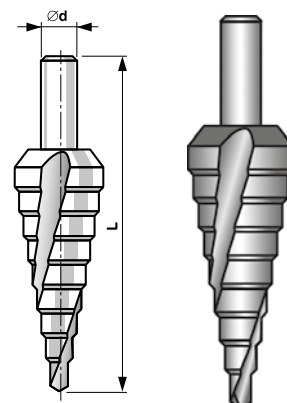

Velikost/Size/Größe/Размер	Ø D	Ø d	L	code HSS	code HSSE
PG 1	6; 9; 11,4; 14; 17,25; 19; 21,25; 26,75	10	77	645 010	695 010
PG 2	6; 9; 12,5; 15,2; 18,6; 20,4; 22,5; 28,3	10	77	645 020	695 020
PG 3	6; 9; 11,4; 14; 17,25; 19; 21,25; 26,75; 30; 33; 35,7	10	100	645 030	695 030
PG 4	6; 9; 12,5; 15,2; 18,6; 20,4; 22,5; 28,3; 30,5; 34; 37	10	100	645 040	695 040